Gateways Proposal - Phase 1

Prepared by: Cllr Gary Harrison

Presented to Full Council 26 January 2022



CHARLBURY TOWN COUNCIL

OBJECTIVE

Following on from the data gathering of the Charlbury Speed Watch (CSW), it appears that some traffic entering Charlbury on its five Gateway roads; Forest Road, Spelsbury Road, Woodstock Road, Banbury Hill and Fawler Road, does not always slow to the 30 mph speed limit. This paper outlines an option to encourage vehicles to obey the 30 mph speed limits as Phase 1 of Charlbury Traffic Calming measures sponsored by the Town Council as part of its strategic plan to make Charlbury more pedestrian and cyclist friendly.

Up to Date Charlbury Speed Watch Data

Location	Max Speed	Average Speed	% Over Limit	Notes
Woodstock Road	52 mph	32 mph	59%	
Forest Road	38 mph	26 mph	7%	
Fawler Road				No data
Spelsbury Road	43 mph	28 mph	0%	Within 40mph Zone
Banbury Hill (Enstone Rd)	43 mph	22 mph	54%	Within 20mph Zone

GOALS

The goal of this Phase 1 Solution is to introduce visual measures, which have been proven many times elsewhere, to produce speed reductions of up to 15 mph. The aim is to implement these solutions as quickly as possible and to then ask CSW to measure the results obtained before deciding on the solutions for further phases.

PROPOSED SOLUTION

Often used as part of gateway schemes, Dragon's Teeth provide a visual change and a perceived narrowing of the road. They are suitable for village/town entry points. They would be used at the 5 Gateways to Charlbury previously mentioned and would be accompanied by "30 mph" Roundels where these are currently missing.

References

[DfT Local Transport Note 1/07 March 2007 Section 7 \(Section 7\)](#)

[DfT Traffic Advisory Leaflet 1/00 March 2000](#)

[DfT Traffic Advisory Leaflet 13/93 December 1993](#)

QUOTE OBTAINED FROM OCC

DRAGONS TEETH ROAD MARKINGS

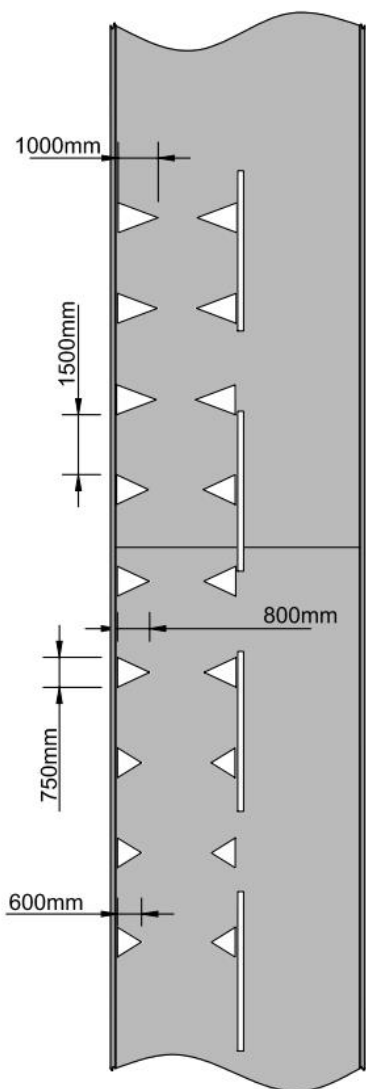

30 OR 40 MPH SPEED LIMIT ARRANGEMENT

30 MPH ROUNDEL



The table below shows the cost of Phase 1 as detailed in this paper.

Description	Work	Cost
Dragons Teeth Road Markings	5 x Dragons Teeth Locations @ £239.48	£1,197.40
Elongated 30 Mph Roundel	2 x 30 Mph @ £59.88	£119.76
Stop & Go Full Day	2 x Stop & Go Day @ £524.69	£1,049.38
Total (Excl VAT)		£2,366.54

VISUALISATIONS

BANBURY HILL



Before



After

SPELSBURY ROAD



Before



After

WOODSTOCK ROAD



Before



After

CHARLBURY TOWN COUNCIL

FAWLER ROAD



Before



After

FOREST ROAD



Before



After

LOCATIONS

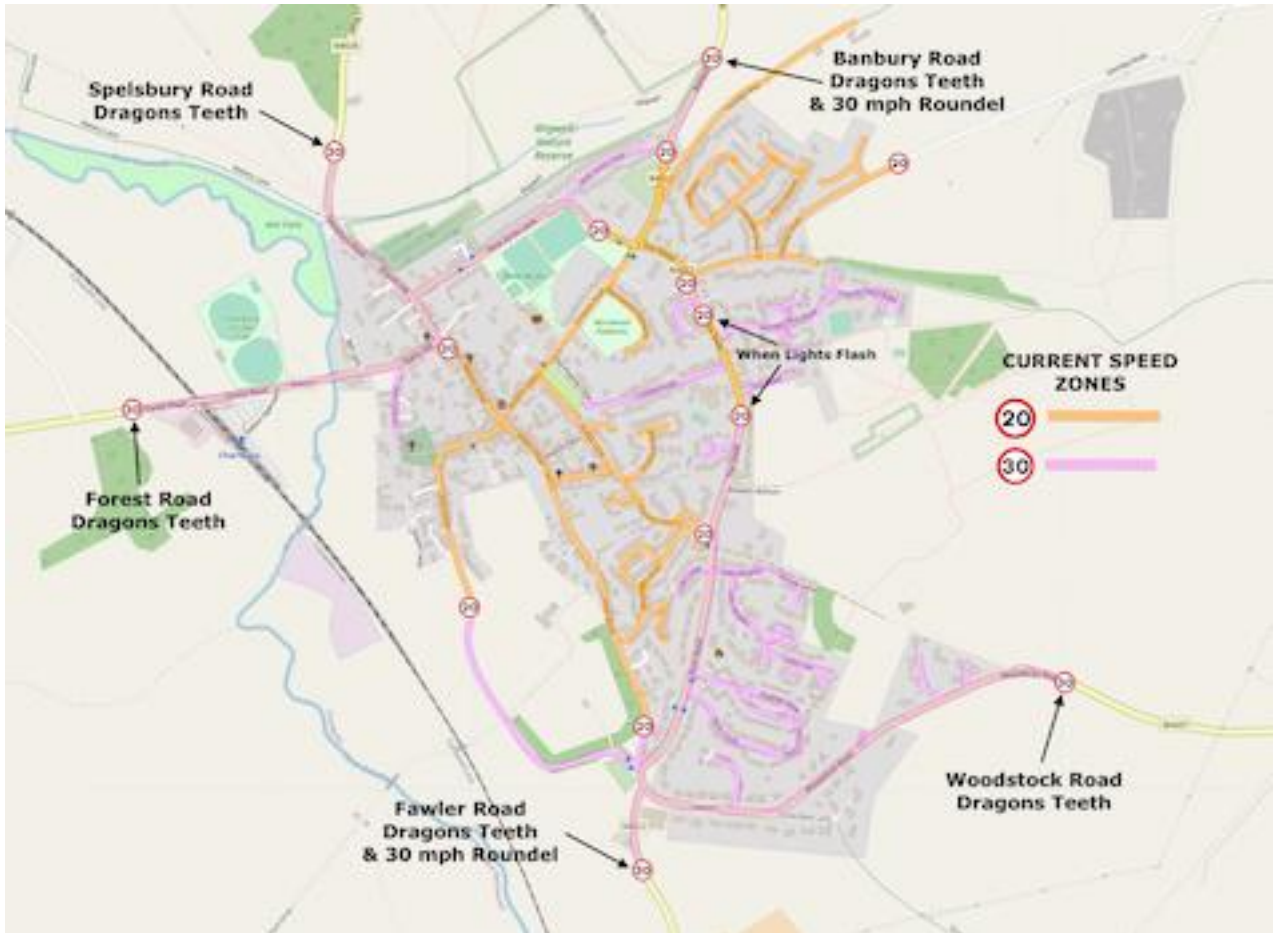

RECOMMENDATIONS

That the Charlbury Town Council adopt the proposals contained in this paper in their entirety and proceed to contract with OCC to complete the associated quoted works asap.

That Charlbury Speed Watch be asked to survey speeds at these 5 sites after the works are complete.